



TECHNICAL REQUIREMENTS

QUEENSHOW

FEBRUARY 2026

Stage

We require a clean, empty stage that meets the country's technical standards. The minimum size of the stage is 10 x 6 m and it must be free of obstacles such as stand legs, cases and racks. For outdoor events, the stage must be completely covered, including the sides. There must be stairs to the stage from both sides.

Parking

We request permission and parking spaces for the following:

- three vans (backline 1/3, backline 2/3 and drum riser with built-in lights 3/3)
- one or two passenger cars
- *plus one or two vans or trucks if the group is supplying the sound and lighting equipment.*

Unloading/loading

When the equipment/band arrives, we will ask for at least two helpers if there is close and barrier-free access to the stage; **in other cases, we will ask for four helpers.** If access is more difficult, for example if there are stairs, long distances or other obstacles, there may need to be more helpers.

Doll's House/Changing room near the stage

The show features the distinctive period costumes typically seen at concerts. Therefore, it is necessary to create a dressing room as close to the stage as possible. Ideally, it should be on the piano side, as shown in the stage plan. We require lighting, a mirror, two tables and five chairs, as well as a 230 V socket for a hairdryer and an electric kettle. Outside, this could be a separate tent measuring at least 3 x 3 metres.

Backdrop

The band will bring its **own backdrop, measuring 8 x 6 metres.** Please prepare a way to hang it, using pipes, trusses, etc., depending on the type of event.

Backline

The Queenshow is the only tribute band in the world that uses the same musical instruments as Queen did at their concerts. **The band has a very rare backline from that period,** which is used exclusively for the Queenshow concert. Setting up the backline takes approximately 1 hour (this does not necessarily take place on stage), and dismantling it takes a further 1 hour. The sound check takes approximately 30–45 minutes. Please take this into account when creating the event schedule.



Drum riser

The band will bring its own drum riser with lights, measuring 5 x 3.5 x 0.8 metres (width, depth, height). If this is not possible, please prepare a safe drum riser with the following dimensions: 3 x 2 m, height 0.3 - 0.6 m.

PA system

We require **a high-quality sound system that is tuned to produce loud rock music** across the entire frequency range. It should provide even coverage of the auditorium and a volume level of **110 dB** in the FOH. We would prefer a suspended system with enough speakers to cover the entire audience area, including the front rows and balconies. **Please consult us in advance.** Local staff must be present throughout the entire production (rehearsal and concert). The band's sound engineer must have access to the system settings.

Stage sound

The band provides its own in-ear monitoring system and stage monitors. They also bring their own microphones, stands and XLR cables. **Please provide 230 V sockets** that meet the required standards for connecting the backline, as detailed in the attached stage plan.

FOH

The band always travels with its own sound engineer and mixing console. Please prepare the following for the band:

- **a space** for the mixing console (e.g. a case or table under the console);
- **a 230 V** power outlet;
- **two functional Ethernet cables** with a minimum **CAT5E** standard (ideally with EtherCon connectors) for connection to the stage box on stage. If the venue is outdoors, the space must be covered.

Lights

Please provide high-quality lighting and smoke machines (preferably hazers), as well as an experienced and perceptive lighting technician. Please follow the band's instructions.

The band uses a drum riser with three lighting circuits and will bring its own dimmers. A 3 x 230 V/16 A connection is required behind the drum riser.

The band uses two vertical smoke machines, which require a 1 x 230 V/16 A connection, divided between the left and right sides of the riser.

For separate concerts, the band provides its own lighting technician and lighting console. If agreed, they will also bring their own lights (see light plot). **Please consult the connection and possibilities of local lights in advance.**



Electrical connection:

Sound:

- 1 x 230 V/16 A for backline (plus extension cords according to the stage plan);
- 1 x 230 V/16 A for the stage box on stage and the FOH console overhead.

Lighting:

- 3 x 230 V/16 A for the drum riser (dimmers to be supplied by the band);
- 1 x 230 V/16 A for the vertical smoke (plus extension cords).

Doll's house/changing room near the stage:

- 1 x 230 V/16 A for hairdryers and other appliances (e.g. kettles).

If the band is supplying the lighting and sound, we will need:

- 400 V/63 A or 32 A for the lights and stage;
- 400 V/32 A for the sound.

Summary:

- Stage: at least **10 x 6 m**
- Traverse, pipe or other suspension for our **8 x 6 m backdrop**, at least 5 m above stage level
- Nearest possible place for unloading/loading, ideally with barrier-free access to the stage
- Minimum of 2 helpers, **ideally 4, for unloading before and loading after the concert**
- Dressing room closest to the stage, equipped with mirrors, tables and chairs, with 230 V/16 A electricity
- 1 x 230 V/16 A **electrical distribution for backline** (see stage plan), 1 x 230 V/16 A for stage box on stage and FOH console in the overhead
- **2 x Ethernet cable between FOH and stage**
- 3 x 230 V/16 A for dimmers (drum riser), 1 x 230 V/16 A for vertical smoke Machines
- A sufficiently **powerful and well-tuned PA system** with attendants
- **Concert lighting** with a lighting technician, unless the band brings their own
- If the band does not provide its own riser measuring 5 x 3.5 x 0.8 metres (W, D, H), a riser measuring 3 x 2 x 0.3–0.6 metres (W, D, H) must be provided instead.
- **Good mood and helpfulness**

Contact:

Please consult all technical requirements in advance. We care about every concert. We can agree on and adapt the requirements to a certain extent. We look forward to working with you.

Sound engineer: Jozef Štefanatný, sound@queenshow.sk, +421 903 569 169
Lighting Technician: Dávid Chudoba, light@queenshow.sk, +421 948 369 045

QUEENSHOW light plot 2025

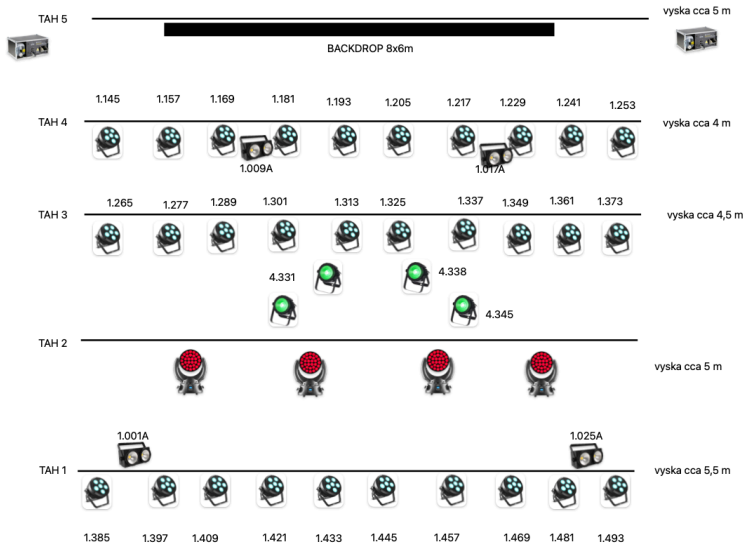

- 30x Cameo Root PAR 6
- 4x WASH DTS NICK1201
- 4x BLINDER 2eye led
- 2x hazer
- 4x Eurolite LED PARTY spot COB
- 2x vertical smoke
- 3x dimmers for drum riser

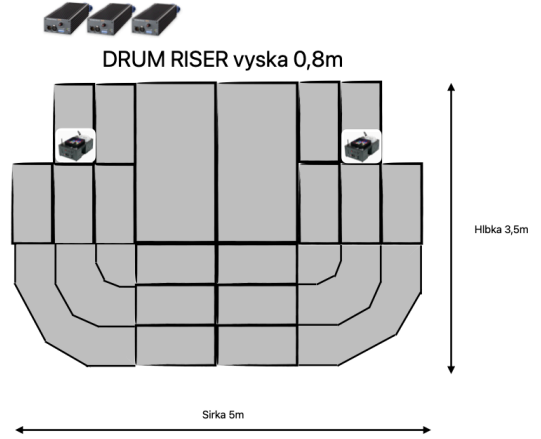

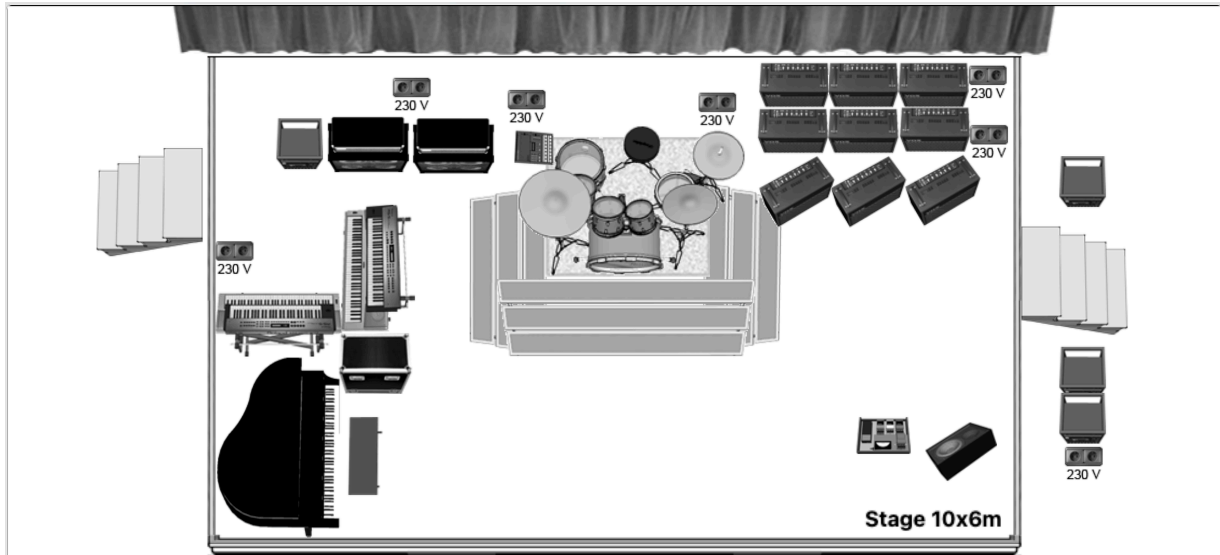

Queenshow Stage Plot 2025

1. Kick IN	B91	9. FT 1	E904	17. BASS	DI-BOX	25. LEAD VOCAL	565	33. JUPITER 50L	DI-BOX
2. Kick OUT	B52	10. FT 2	E904	18. VOX L	545	26. LEAD PIANO	565	34. JUPITER 50R	DI-BOX
3. SD TOP	SM57	11. ROTO 1	E904	19. VOX M	545	27. LEAD V MON	Y	35. YAMAHA DX7	DI-BOX
4. SDBOT	SM57	12. ROTO 2	E904	20. VOX R	545	28. LEAD V PNO	Y	36. JUNO 60	DI-BOX
5. HH	FC4	13. OH L	MK012	21. AG OVATION	DI-BOX	29. DRUM VOC	OM 6	37. VOCO VP330L	DI-BOX
6. RT 1	E904	14. OHR	MK012	22. spare		30. GTR VOC	OM 6	38. VOCO VP330R	DI-BOX
7. RT 2	E904	15. PAD L	JACK	23. TELECASTER	DI-BOX	31. talk back FOH	switch	39. YAMAHA CP4L	DI-BOX
8. RT 3	E904	16. PAD R	JACK	24. LESS SPECIAL	DI-BOX	32. CLICK	DI-BOX	40. YAMAHA CP4R	DI-BOX

Queenshow input list 2025				18m	20m	12m	23m	DRMS1 USLC in1-12 18m		DRMS2 USRC in13-24	
IN	Name	MIC/DI		DR 1	DR 2	GTR	KEY	IN	IN	IN	IN
1	Kick in	b91		1				1	13	Floor Tom 1	9
2	Kick out	b52		2				2	14	Floor Tom 2	10
3	Snare top	sm57		3				3	15	Rototom 1	11
4	Snare bottom	sm57		4				4	16	Rototom 2	12
5	Hi Hat	FC4		5				5	17	Overhead Left	13
6	Tom 1	e904		6				6	18	Bass guitar	17
7	Tom 2	e904		7				7	19		
8	Tom 3	e904		8				8	20		
9	Floor Tom 1	e904			13			9	Overhead Right	14	21
10	Floor Tom 2	e904			14			10	Vocal Drums	29	22
11	Rototom 1	e904			15			11	CLICK	32	23
12	Rototom 2	e904			16			12			24
13	Overhead Left	mk012			17						
14	Overhead Right	mk012	9								
15	Electric Drum Left	jack-xlr					25	25	Electric Drum Left	15	37
16	Electric Drum Right	jack-xlr					26	26	Electric Drum Right	16	38
17	Bass guitar	Di box			18			27	Vox Left box	18	39
18	Vox Left box	545					27	28	Vox Center box	19	40
19	Vox Center box	545					28	29	Vox Right box	20	41
20	Vox Right box	545					29	30	AG Ovation 1	21	42
21	AG Ovation 1	di					30	31	spare	22	43
22	spare							32			44
23	Telecaster W	Di box 8					48	33	Yamaha DX7/2	38	45
24	GTR Key/less specia	Di box 7					42	34	Vocal Guitar	30	46
25	Lead Vocal	565					45	35			47
26	Vocal Piano	565					46	36			48
27	Lead Vocal MO	Y from 25									
28	Vocal Piano MO	Y from 26									
29	Vocal Drums	om5	10								
30	Vocal Guitar	om5					34				
31	TALK BACK FOH						Desk lokal input				
32	CLICK	3,5 - XLR	11								
33	Jupiter L 50	Di box 1					37				
34	Jupiter R 50	Di box 2					38				
35	Yamaha DX7/1	Di box 3					39				
36	Roland Juno 60	Di box 4					40				
37	Vocoder VP330	Di box 5					41				
38	Vocoder VP330	Di box 6					33				
39	Yamaha CP4 L	xlr					43				
40	Yamaha CP4 R	xlr					44				
ST1	INTRO	Usb from desk or MacBook									

GTRS SL in25-36 12m			KEYS SR in37-48 23m		
IN	IN	IN	IN	IN	IN
25	Electric Drum Left	15	37	Jupiter L 50	33
26	Electric Drum Right	16	38	Jupiter R 50	34
27	Vox Left box	18	39	Yamaha DX7/1	35
28	Vox Center box	19	40	Roland Juno 60	36
29	Vox Right box	20	41	Vocoder VP330	37
30	AG Ovation 1	21	42	Guitar Amp Key	24
31	spare	22	43	Yamaha CP4 L	39
32			44	Yamaha CP4 R	40
33	Yamaha DX7/2	38	45	Lead Vocal	25
34	Vocal Guitar	30	46	Vocal Piano	26
35			47	Vocoder VP330	38
36			48	Telecaster W	23

IEM outputs from desk to IEM G4		
AUX	Output	Destination
1	AUX 1	KEY L
2	AUX 2	KEY R
3	AUX 3	MAIN L
4	AUX 4	MAIN R
5	AUX 5	BASS L
6	AUX 6	BASS R
7	AUX 7	DRMS L
8	AUX 8	DRMS R
9	AUX 9	GTR L
10	AUX 10	GTR R
11	AUX 11	TECH L
12	AUX 12	TECH R
13	AUX 13	GTR